

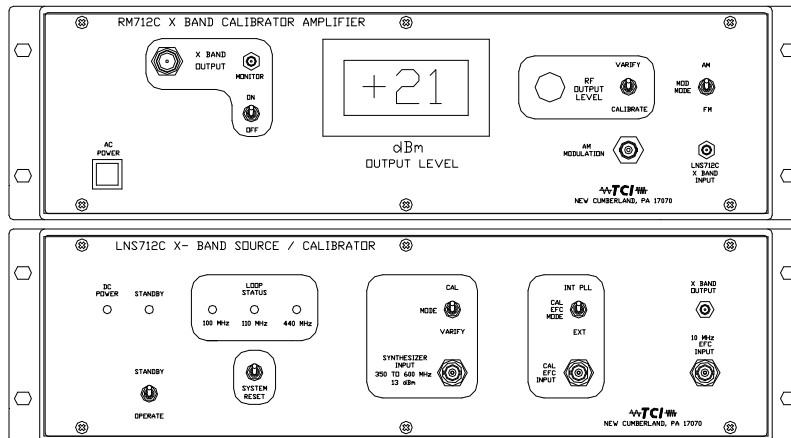

ADVANCED NOISE TECHNOLOGY

LNS712C / RM702

Ultra Low Noise Carrier Signature Source With Calibrator Amplifier



Applications:

- Noise Calibration Transfer Reference
- Radar Exciter Development Standard Missile, Sea Sparrow, and AAMRAM Noise Calibration Standard
- Mk39 Mod 5 Mk666 Mod 0, Calibration Standard

Specifications:

RF Frequency Range:	9.32 to 9.72 GHz and / or 10.12 GHz to 10.52 GHz
RF Output Power Level:	+20 dBm min
Conversion Line Frequency:	9.92 GHz
Synthesizer Input Frequency:	220 to 600 MHz
Synthesizer Input Level:	+10 dBm, ± 2 dB
Output VSWR:	1.5:1 max into 50 Ohms
Harmonics:	-50 dBc
Coherent Spurious:	-60 dBc, < 100 MHz
Non-Coherent Spurious:	-90 dBc
AC Line Related Spurious:	-65 dBc
Conversion Sidebands:	-60 dBc
Operating Temperature:	+25° C, ± 15 ° C
Internal Reference Frequency:	10.000 MHz
Frequency Stability:	$\pm X 10^{-9}$
Customer Output Level:	+10 dBm
Harmonics:	-26 dBc
Internal Calibration Source:	440 MHz, (Phase Locked to Reference)
Electronic Tuning Range:	± 6 PPM, ± 10 VDC (Un-Locked)
Un-Locked Frequency Stability:	± 5 PPM

Techtrol Cyclonetics Inc.

815 Market Street New Cumberland, PA 17070

Phone: (717) 774-2746 Fax: (717) 774-6799

Website: www.tci-ant.com E-mail: Sales@tci-ant.com

TECHNICAL DESCRIPTION

The LNS712C Ultra Low Noise Source is useful for many applications where extremely Low Noise is required, such as calibration of noise measurement systems in the C, X and Ku bands. Both AM and PM noise signatures are provided. The system is internally phase locked to a very low noise 10 MHz, high stability reference. The 10 MHz reference signal is available from an external output. The frequency scheme generates an Ultra Low Noise 9.92 GHz carrier frequency for X and Ku band outputs, and 4.96 GHz for C band outputs. The low noise carrier is then used to up or down convert to the desired frequency band. An external synthesizer can be used to produce an output frequency band of 9.32 to 9.72 GHz or 10.12 to 10.52 GHz. The required synthesizer frequency range is 200 to 600 MHz. The LNS712C system contains a 440 MHz (10.23 GHz) very low noise internal calibration oscillator so that the LNS712C noise performance can be measured. If the noise from the VHF source used for up or down conversion is sufficiently low enough in noise, the resulting carrier will have little or no noise degradation. (See the LMN713 data sheet for a low noise performance synthesizer).

The internal 10 MHz reference and the 440 MHz calibration oscillators can be electrically tunable from the front panel to provide for noise measurement phase locking. The internal 10 MHz reference oscillator provides approximately ± 2 PPM tenability with the 440 MHz calibration source providing a ± 6 PPM.

The preferred method of phase locking for noise measurement is to use the 440 MHz calibration source, because the internal crystal oscillator is only multiplied by 4, whereas the 10 MHz reference oscillator is multiplied by approximately 992. Since the electrical tuning rate of the 440 MHz calibration oscillator is only multiplied by 4, a much narrower phase lock can be achieved when measuring phase noise. The LNS712C has many variations to meet your specific need.

The white paper entitled "Phase Noise Calibration" by William McMillan, Naval Calibration Laboratory, Yorktown, VA explains implementation of an AM and PM calibration system for calibration of the Mk666 Mod 0 CWI noise measurement instrument. This paper is available from TCI.

AM / PM NOISE PERFORMANCE

The phase noise data below reflects the PM and AM noise of the 9.920 MHz internal LO frequency and the result of up conversion to 10.36 GHz using the internal 440 MHz Calibration Source. The noise being reported is the noise of the 9.920 GHz LO frequency source as the 440 MHz source is much lower in noise. Therefore, if an external source is summed or differenced with the internal LO, the results can be calculated.

9.920 or 10.36 GHz Noise Performance:

	PM Noise	AM Noise
10 Hz:	-65 dBc/Hz SSB	-112 dBc/Hz
100Hz:	-87	-122
1 KHz:	-114	-132
10 KHz:	-133	-142
100 KHz:	-140	-152
1 MHz	-142	-162

A 10 MHz Customer output is provided to allow other instruments to remain coherent to the LNS712C. The data listed below represents the typical noise from the buffered 10 MHz output.

	PM Noise
10 Hz:	-148 dBc/Hz
100 Hz:	-163
1 KHz:	-165
10 KHz:	-165
100 KHz:	-165

Connectors: SMA-F (RF output, Reference Output)
BNC (Electrical Tuning)

Operating Power: 120 / 240 VAC, 57 to 63 Hz
Approximately 175 Watts

Techtrol Cyclonetics Inc.

815 Market Street New Cumberland, PA 17070

Phone: (717) 774-2746 Fax: (717) 774-6799

Website: www.tci-ant.com E-mail: Sales@tci-ant.com

The system is contained in two 5 .25" high X 19" wide X 17" deep rack cabinets. One rack cabinet contains the power supplies to operate the LNS712C to isolate the magnetic field of the power transformers from the low noise circuitry. The power supply cabinet, designated model number PS712A, provides space for customer specific additions to the system.

Note: The Am and PM noise of each system is measured and a report provided with the unit. To allow PM noise to be measured, two units must be available for special frequency schemes.

Variations to the LNS712C are almost infinite. Each system is designed to meet a customer's exact requirement. The information provided above is a general outline of the system and therefore is incomplete relating to details. If we can be of assistance, please contact the factory directly.

OPTIONS

P2	+20 dBm Output Level (Standard)
P3	+30 dBm Output Level
AM	Improved AM Performance
FD	Dual Band Up / Down Conversion
M1	AM & PM 50 KHz Tone Modulation
AT	Variable Attenuator 0-30 dB, 1 dB Step
F1	9920 MHz (Standard)
F2	9700 MHz

Any single frequency 8.0 GHz to 12.4 GHz is available.

The FD option provides two 500 MHz bands, 9220 MHz to 9720 MHz and 10.170 GHz to 10.670 GHz and 2 calibration frequencies.

OPTION AM, AM NOISE PERFORMANCE

	AM Noise
10 Hz:	-120 dBc/Hz
100 Hz:	-130
1 KHz:	-140
10 KHz:	-147
100 KHz:	-153
1 MHz:	-161

PLEASE CONTACT US WITH YOUR SPECIAL APPLICATIONS

Techtrol Cyclonetics Inc.

815 Market Street New Cumberland, PA 17070

Phone: (717) 774-2746 Fax: (717) 774-6799

Website: www.tci-ant.com E-mail: Sales@tci-ant.com

Outline Drawing

FRONT PANEL LNS712 FOR TECHTROL CYCLONETICS

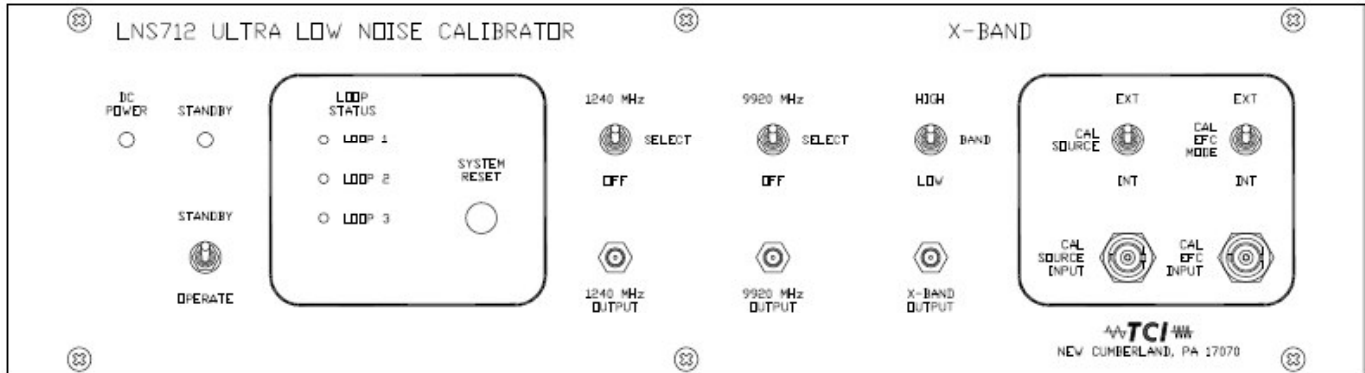

REAR PANEL LNS712 FOR TECHTROL CYCLONETICS

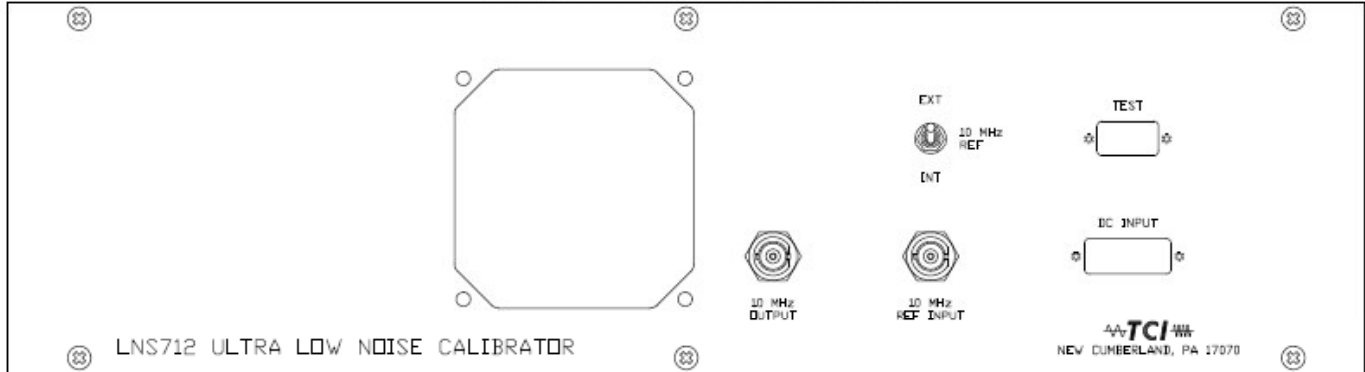

Techtrol Cyclonetics Inc.

815 Market Street New Cumberland, PA 17070

Phone: (717) 774-2746 Fax: (717) 774-6799

Website: www.tci-ant.com E-mail: Sales@tci-ant.com